

Contributions to the Development of Oil Consumption / Oil Dilution



Contents



- Application Areas
- Proportion of Oil Consumption
- Measuring Method
- Oil Consumption – Entire Engine
- Oil Consumption – Components
- Oil Dilution Measurement

- Oil Consumption Analyses /
Separate Analyses of Sub-Assemblies (e.g. Turbo Chargers)
- Ageing /
Fault Simulation on Fuel Injection System
- Effect of Oil Dilution
- Oil Dilution / Consumption
using alternative fuels and lubricants
- Testing of Fuels and Lubricants loaded with Additives

Proportion of Oil Consumption

- Approx. 3/4 of oil consumption is transmitted by the cylinder wall
- Oil consumption can be overlapped by fuel ingress (cold start, post-injection)
- Rise of turbocharger oil consumption with increasing mileage

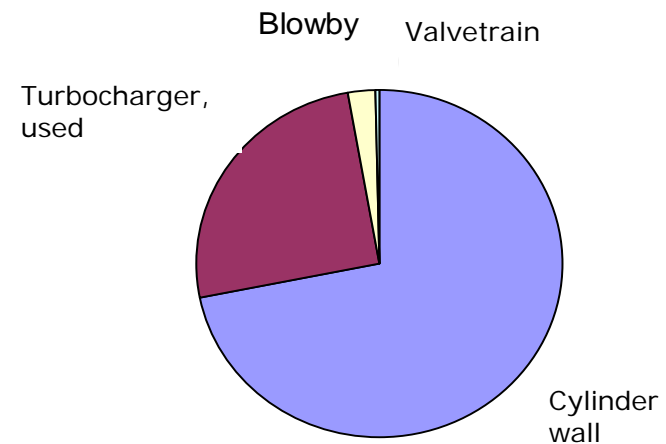
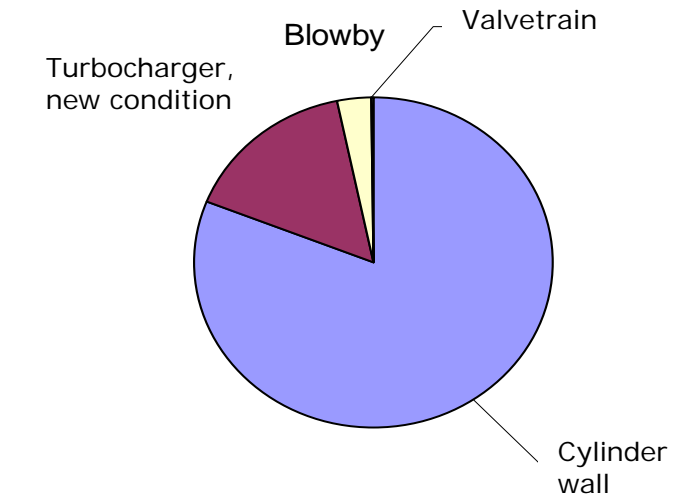

Relative proportion of engine oil consumption
Source: FVV-Vorhaben Nr. 748

Advantages of Radiotracer Method:

- Real-time data logging
- High resolution:
consumption measurement > 0.1 g/h
dilution measurement > 0.01 %/h
- Tracer embedded in oil molecules,
i.e. no modification to tribological
characteristics
- Contamination-free test sample after
test end

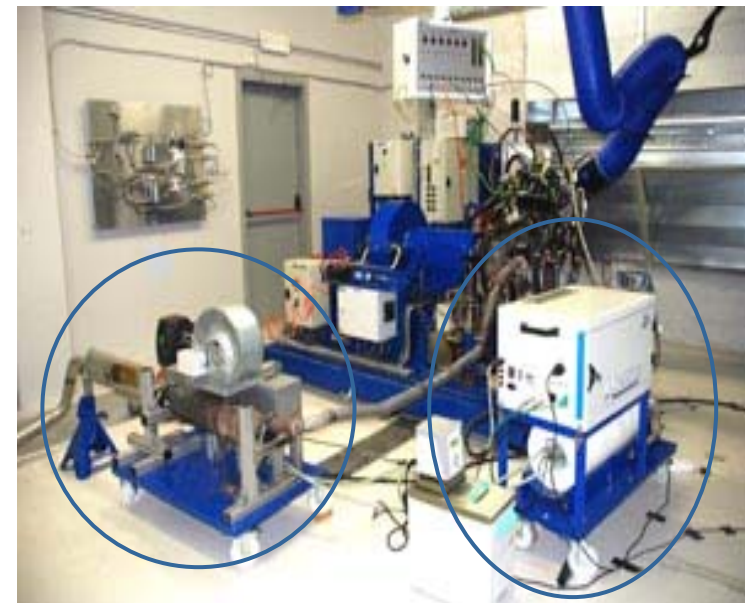

Oil Consumption

Oil Dilution

Functional Diagram of Oil Consumption Measurement

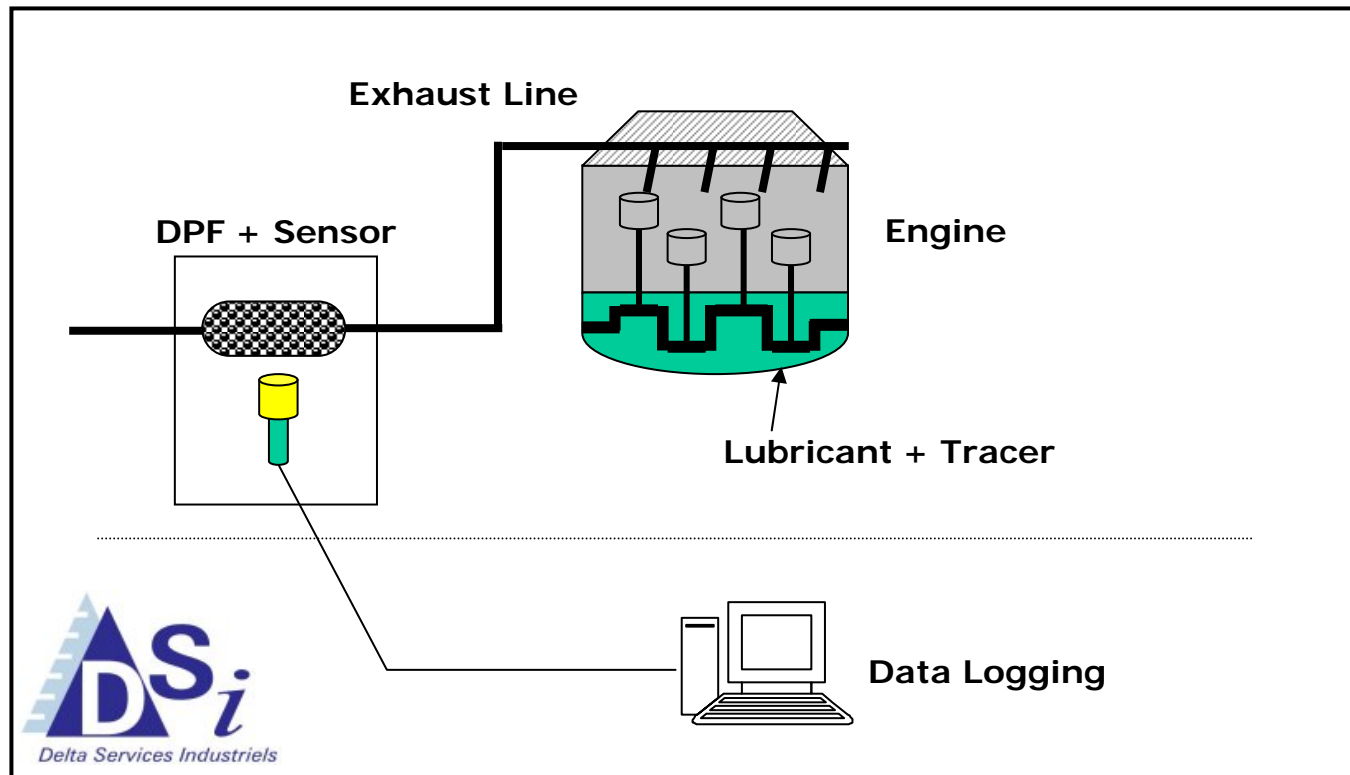

Oil Consumption / Entire Engine

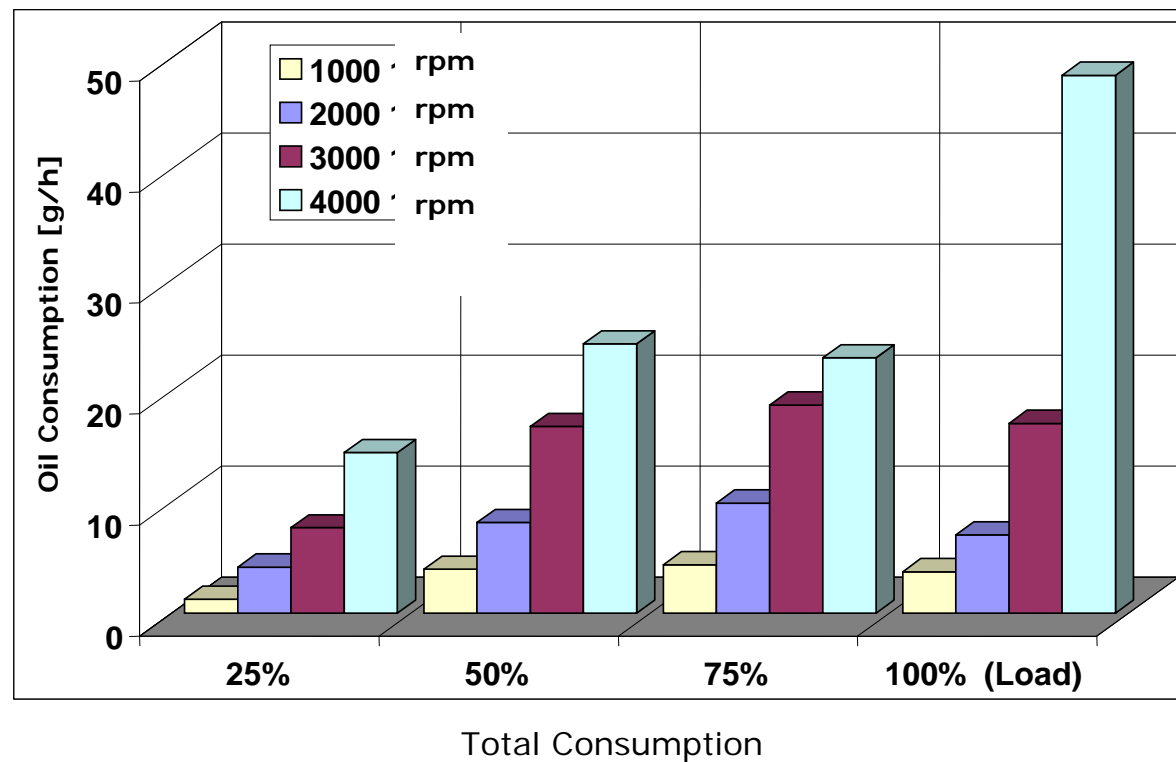

Oil Consumption / Components

Oil Consumption Measurement Turbocharger

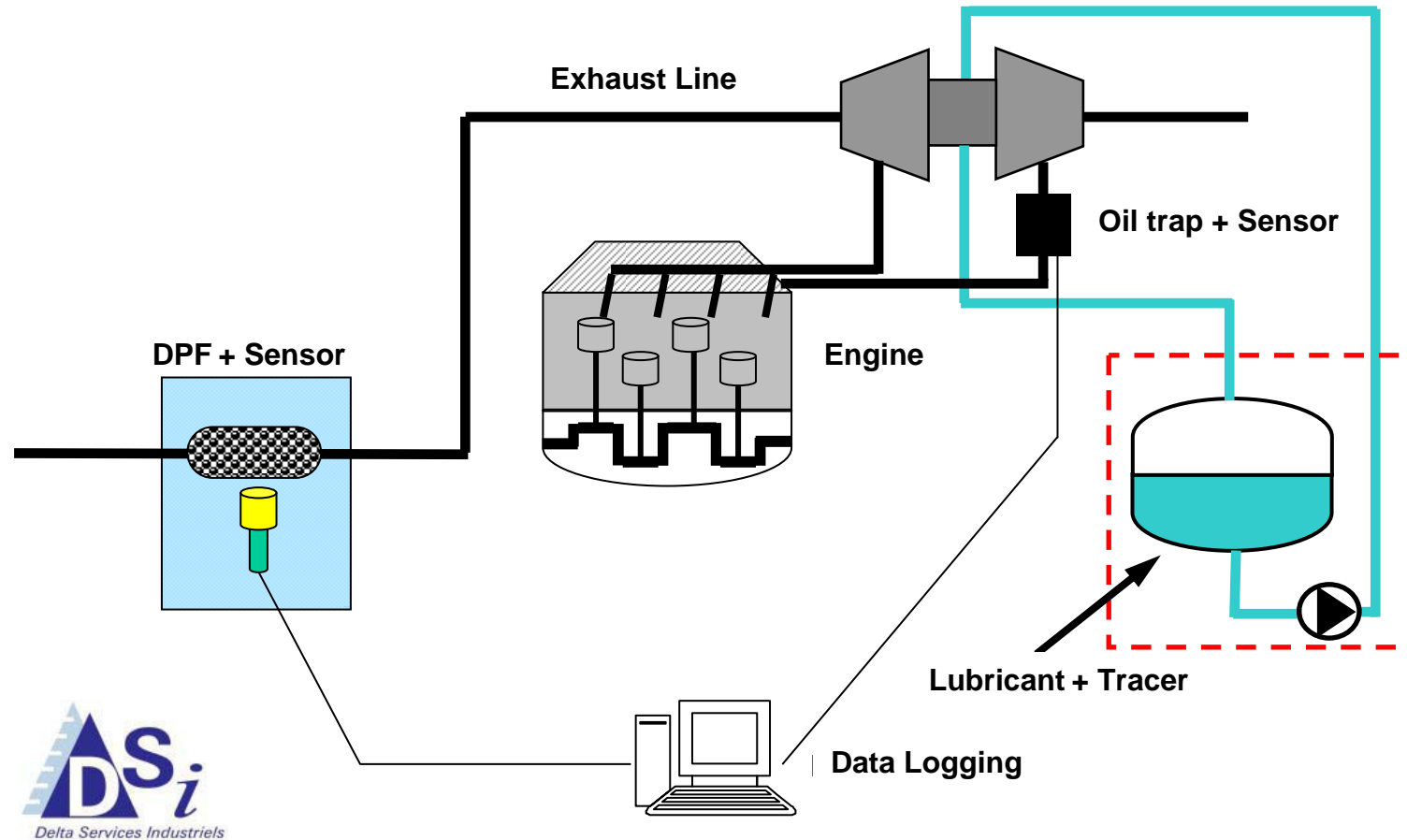

Oil Consumption / Components

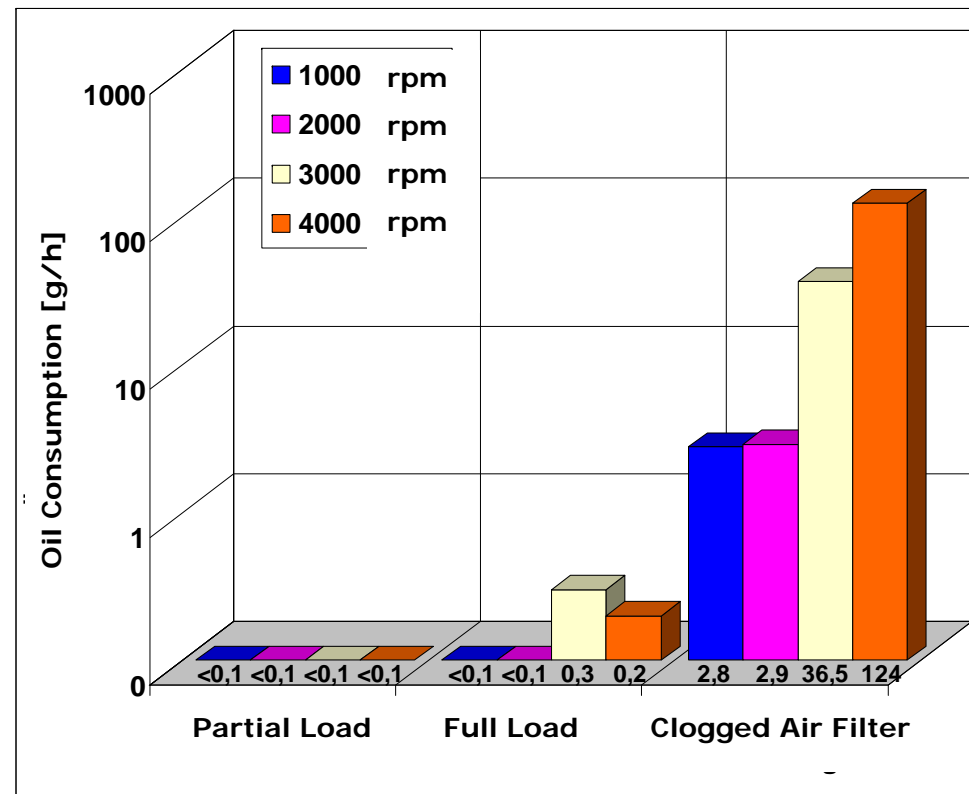

Consumption on Diesel Passenger Car (Turbo Charger)

Oil Dilution Measurement

Functional Scheme

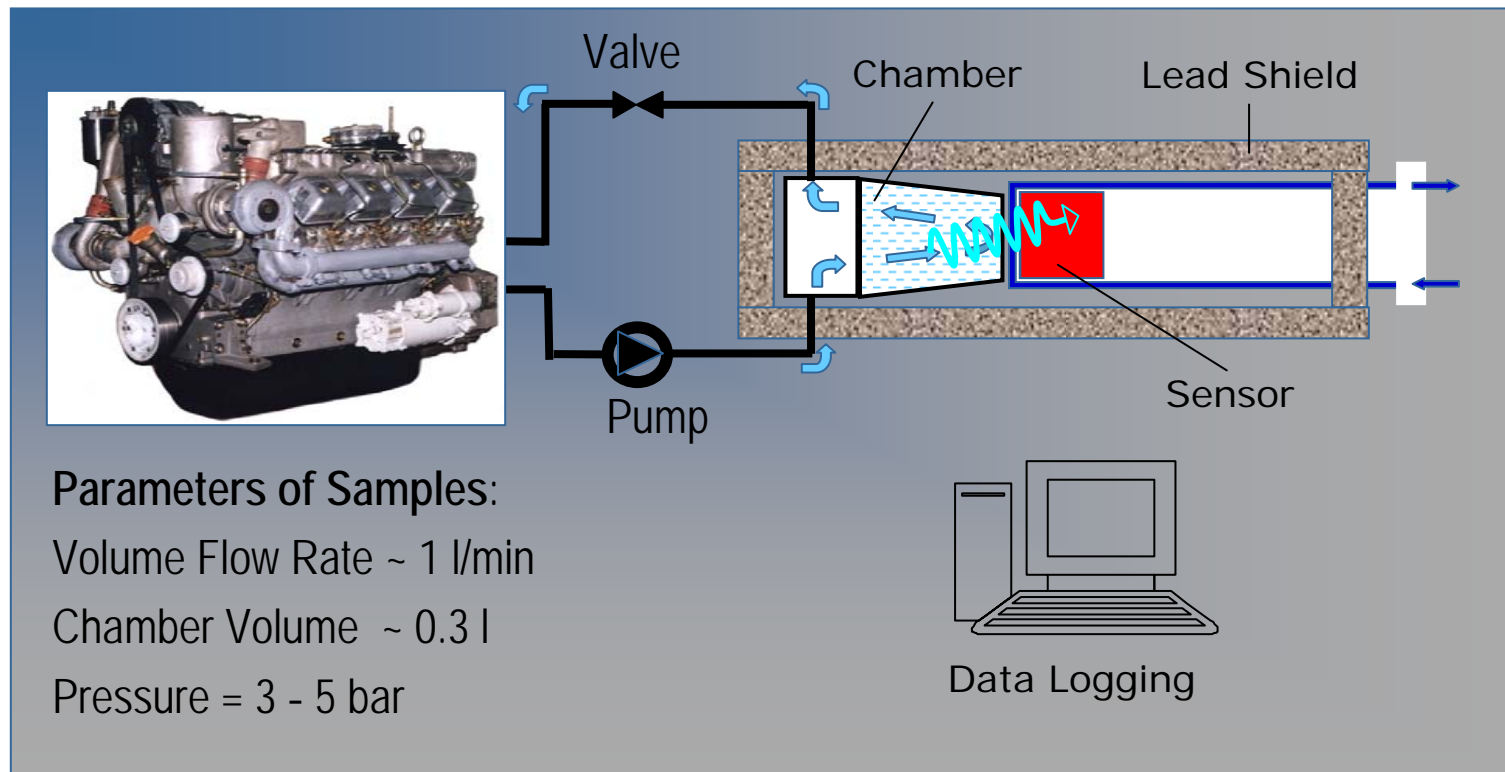

Scheme of Oil Dilution Measurement

Range of Application

- Optimization of DPF regeneration process
- Cold start
- Oil dilution for wear analyses
- Detection of non-evaporating fuel fractions

Oil Dilution Measurement

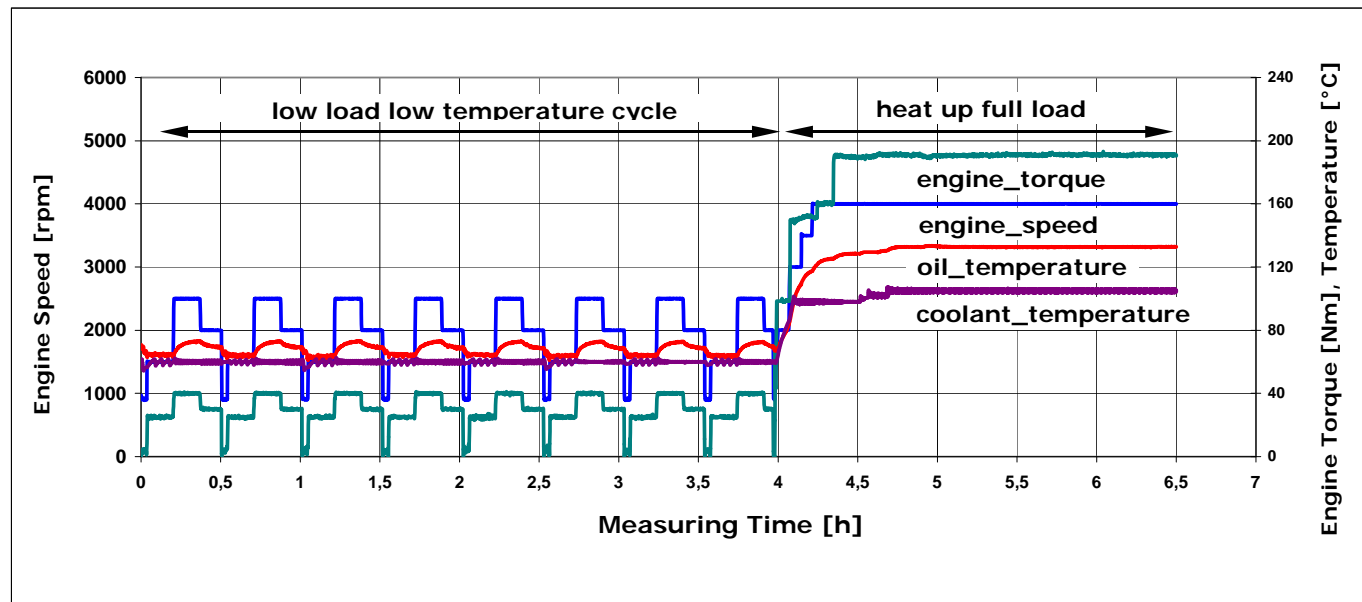

Cycle for Oil Dilution Measurement (Partial Load following Full Load)

Oil Dilution Measurement

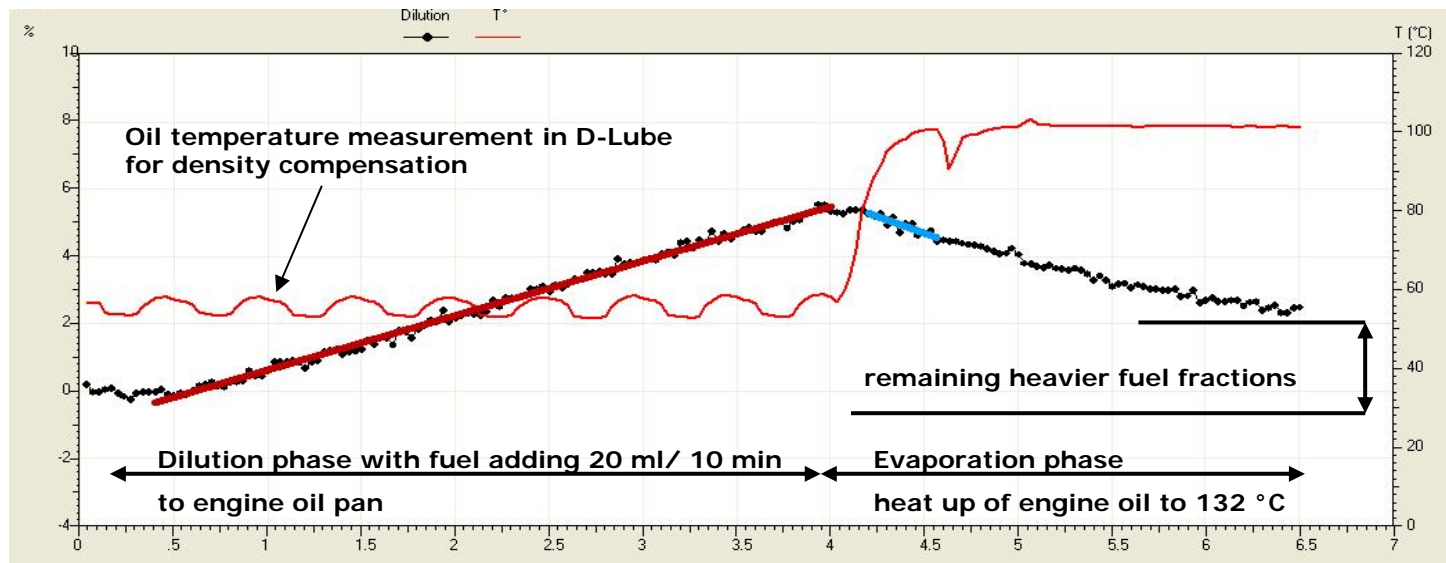

Online Graph of Oil Dilution Measurement during Dilution Cycle
(Oil Dilution with following Evaporation Phase)

Locations



KST Motorenversuch GmbH & Co. KG
Bruchstraße 24 - 32
67098 Bad Dürkheim
Germany
Telephone: +49 6322 - 799 0
Fax: +49 6322 - 799 353
E-Mail: info@kst-motorenversuch.de
Internet: <http://www.kst-motorenversuch.de>



GEVA Gesellschaft für Entwicklung und Versuch Adlershof mbH
Willy Wolf-Bau
Friedrich-Wöhler-Straße 1
12489 Berlin
Germany
Telephone: +49 30 63 92 - 74 10
Fax: +49 30 63 92 - 74 70
E-mail: service@geva-adlershof.de
Internet: <http://www.geva-adlershof.de>