

C-LUBE :
REAL-TIME OIL CONSUMPTION MEASUREMENT
ON COMBUSTION ENGINES

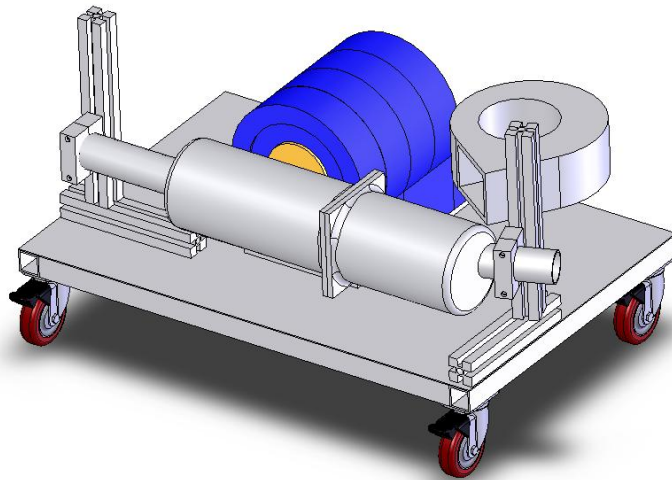

TECHNICAL BROCHURE

NEW METHODOLOGY FOR REAL-TIME ENGINE OIL CONSUMPTION MEASUREMENT

On-line measurement of oil consumption is of interest, in light of the new environmental regulations imposed on today's high-performance engines.

Lubricant consumption has a negative impact on the environment, but it also reduces the life-time of post-treatment systems by poisoning catalysts and clogging particle filters.

A new method was recently developed and patented by DSi Belgium and TOTAL France for monitoring oil consumption on running engines. It is based on lubricant labeling using new radiotracer compounds, which are made representative of the distillation interval of the base oil.

Oil consumption measurement is performed in the exhaust line where tracer residues are trapped and monitored during engine operation.



MEASUREMENT PRINCIPLE

Engine oil is labeled by adding a radiotracer to the engine oil, and a monitoring system is installed near the exhaust line where the marker will be trapped. During engine operation the tracer is burned proportionally to the lubricant. The measurement consists of monitoring, in real-time, the amount of tracer trapped in the exhaust line. The amplitude of the detected signal is proportional to the oil consumption.



**REAL-TIME OIL CONSUMPTION MEASUREMENT PROBE
INSTALLED IN THE EXHAUST LINE**

The new methodology is reliable and very sensitive for research and development applications. It offers significant advantages over other methods, including:

- **On-line / Real-time results.** Oil consumption for one operating condition is typically acquired in 5 to 15 minutes. Analysis of short transient phases is also possible by increasing the amount of tracer mixed in the oil, or by using repeatable transient data.
- **Engine oil consumption mapping within 1 day.** A real-time, steady-state map is generated within 4 to 6 hours for typical oil consumption rates of 1 to 10 grams/hour.
- **No change in oil properties.** Less than 100 μl of tracer is added to the engine oil pan. The tracer shows no particular chemical reaction with the lubricant.
- **Representative of oil distillation interval.** Several tracer compounds are available, with various boiling points spread over the oil distillation interval. A single tracer can be used for measuring consumption of a particular oil fraction (light, medium or heavy), or a mixture of tracers can also be used in order to be representative of the actual oil distillation interval.
- **No need for low-sulphur fuel.** The use of special fuels is not required.
- **Measuring equipment is compact and easy to use.** Only a filter has to be installed in the exhaust line to trap the tracer. The measuring probe is installed close to the filter and its local data acquisition unit is linked to a remote PC via a USB cable.
- **Applicable on test beds and on moving vehicles.** Two equipment configurations are available, including a compact system for on-board installation on passenger cars, with local data logger for acquisition during road tests.

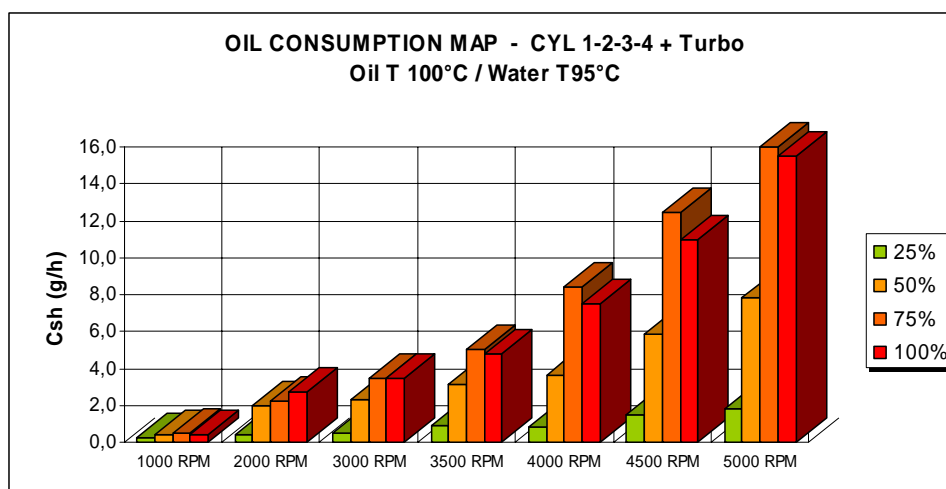

OIL CONSUMPTION MAP ON A 4-CYL TURBO-DIESEL ENGINE

EXAMPLE: OIL CONSUMPTION MEASUREMENT ON A V6 ENGINE

A consumption measurement was performed on a V6 PR gasoline engine. During the experiment two probes were installed near the exhaust line - one per cylinder bank - in order to monitor and to compare consumption of the two banks.

Oil labeling was performed using a radiotracer having a short half-life of ~40 hours. The tracer was a mixture of organic compounds showing the same distillation interval as the base oil contained in the lubricant.

The aim of this short experiment was to show the impact of engine speed and load on oil consumption. Extreme conditions have also been tested, including engine knocking.

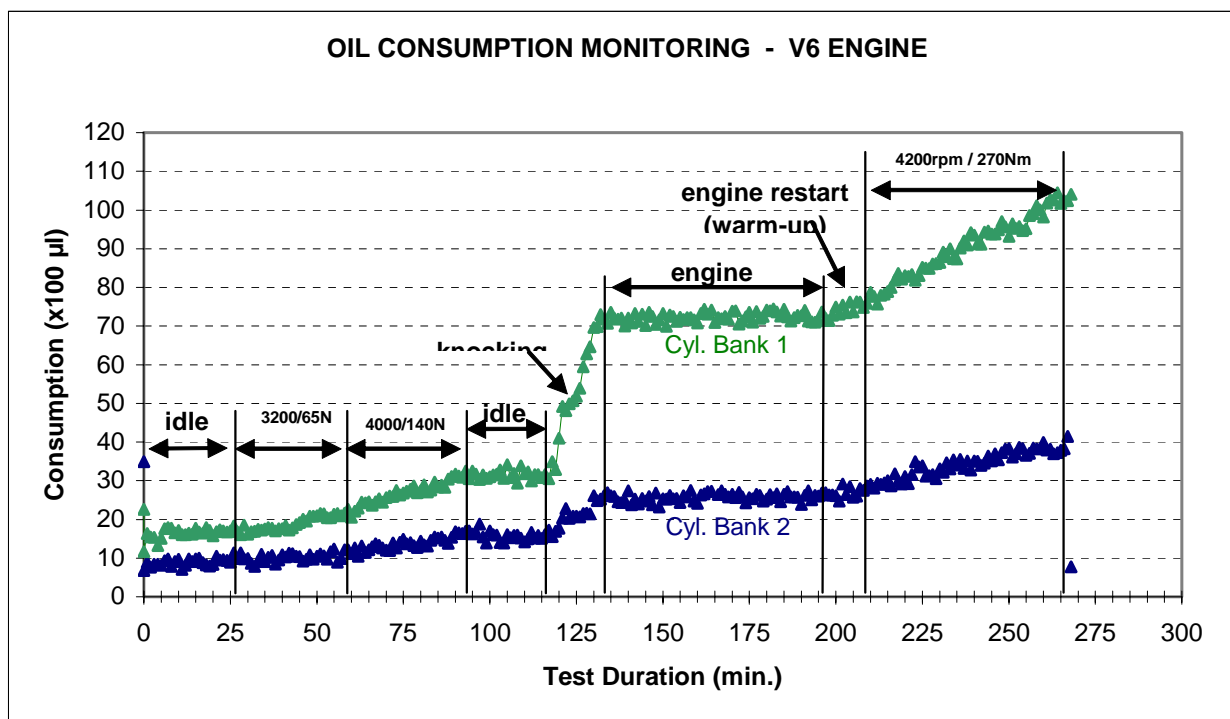

As expected, higher speeds and loads are associated to higher lubricant consumption. It also appears clearly that consumption of cylinder bank 1 is significantly higher than bank 2. Between $t=110$ and $t=130$ min., the sudden oil consumption increase was due to particular conditions that induced engine knocking.

For more information:

Delta Services Industriels (DSi)

Mr. Thierry Delvigne
12 rue Grande Couture,
B-7501 Orcq,
BELGIUM
Tel: +32 69 64 06 04
Fax: +32 69 78 00 79

Web site : www.deltabeam.net
e-mail : infos@deltabeam.net